

ARCOSA

SHORING PRODUCTS

Build-A-Box Modular Trench Shielding System



Tabulated Data
Effective March 15, 2021
Revised July 2, 2025

Applies to the following Manufacturers:

GME Shoring Solutions • Pro-Tect Equipment • Efficiency Production • Cerda Industries

General Information1

Soil Classification.....2

Data Limitations.....3

Configurations4

Assembly.....5

Disassembly.....6

Build-A-Box Arches.....7

Installation & Usage Notes 8-9

2-Sided Box - Panel Selection Chart.....10

3-Sided Box

 Sectional Corner Posts 11-14

 Full Length Corner Posts 15-18

4-Sided Box - Sectional & Full Length Corner Posts..... 19-22

Shield & Spreader Placement.....23

Stacking Guides24

Stacking Build-A-Box on (EPI) Aluminum Trench Shields25

Build-A-Box Guide Frame with Aluminum Sheets26

Build-A-Box Octagon Configuration..... 27-28

Additional CertificationsAppendix A

This tabulated data is a general set of guidelines and tables to assist the competent person in selecting a safety system and the proper shoring or shielding equipment. The competent person has sole responsibility for job site safety and the proper selection and installation and removal of the shoring or shielding equipment.

This tabulated data is not intended to be used as a job specific excavation safety plan, but shall be used by the competent person to supplement his training, his experience and his knowledge of the job conditions and soil type.

1. The Modular Trench Shielding System tabulated data is based on the OSHA Safety requirements defined in 29 CFR, Part 1926, Subpart P - Excavations and Trenches.
2. This data is to be used by a soils engineer, or a competent person. The competent person shall be experienced and knowledgeable of trenching and excavation procedures, the use of modular trench shielding systems, soils identification, and the OSHA standards.
 - a. A trained competent person shall: supervise all excavation operations; ensure that all personnel are working in safe conditions; and have thorough knowledge of this tabulated data. The competent person shall have the authority to stop work when it is unsafe for workers to enter an excavation.
 - b. All personnel shall be trained in correct excavation procedures, proper use of the protective system and all safety precautions.
 - c. Excavations and protective systems shall be inspected a minimum of once each working day and whenever there is a change of soil, water, or other job site conditions.
 - d. All lifting and pulling equipment, including cables, slings, chains, shackles and safety hooks shall be evaluated for suitability and capacity, and shall be inspected for damage or defects prior to use.
3. The competent person shall continually monitor the excavation for signs of deterioration such as seepage of water or flowing soil into the excavation. Promptly de-water any accumulated water and reassess the trench for safety. Changing soil conditions may require adjustments to the shoring system.
 - a. All installation and removal of shielding or shoring shall be from above ground only.
 - b. Do not allow personnel to enter an excavation that is not properly shored, shielded or sloped.
 - c. Personnel shall always work within the shielding or shoring. Personnel shall not stand on the edge of an un-shored excavation.
 - d. All personnel shall enter and exit excavations only within shielded or shored areas.
4. The tabulated data shall only be used for those soil conditions indicated. The data is not considered adequate when loads imposed by structures, equipment, traffic, or stored materials adjacent to the trench exceed the assumed design surcharge loads of 20,000 pounds, or the imposed load of a 2 ft. spoil pile located less than 2 ft. from the edge of the excavation. An engineered shielding or shoring design is required for conditions other than those assumed in the tables.
5. Proper backfill sufficient to stabilize the Modular Shield and to minimize ground surface and/or foundation settlements is required. Where such settlements are not a concern, over digging may be performed, however, the clear distance shall not exceed 6 inches.
6. No vertical or horizontal loads shall be applied to the adjustable strut/spreader or static braces except as specified by the Manufacturer. Any mishandling, such as pounding with the backhoe bucket, will void the tabulated data.

Classification of Soil Types

The soil descriptions for OSHA Type “A”, “B”, & “C” Soils are based on Appendix A to OSHA Subpart P of 29CFR Part 1926, “Excavations and Trenches”. The Type “C-60” Soil referred to in Manufacturer’s Tabulated Data represents a more stable soil condition than the Type “C” described in Appendix A.

Type “A” Soil - Effective lateral weight of **25 PSF** per foot of depth.

Description: Cohesive soil (i.e., silt, silty clay, sandy clay, clay loam) with an unconfined compressive strength of 1.5 TSF (tons per square foot) or greater; or cemented soils such as caliche and hardpan. No soil is Type A if the soil is fissured; subject to vibration from heavy traffic, pile driving or similar effects; has been previously disturbed; or part of a sloped, layered system where the layers dip into the excavation on a slope of four horizontal to one vertical (4H:1V) or greater.

Type “B” Soil - Effective lateral weight of **45 PSF** per foot of depth.

Description: Cohesive soil with an unconfined compressive strength greater than .5 TSF but less than 1.5 TSF; and granular cohesionless soils including angular gravel, silt, silt loam, sandy loam, and in some cases, silty clay loam and sand clay loam; previously disturbed soils except those which would otherwise be classed as Type C; soil that meets requirements for Type A, but is fissured or subject to vibration; dry rock that is unstable; and material that is part of a layered system where layers dip into the excavation on a slope less steep than four horizontal to one vertical (4H:1V), but only if the material would otherwise be classified as Type B.

Type “C-60” Soil - Effective lateral weight of **60 PSF** per foot of depth.

Description: Soft cohesive to moist soil with an unconfined compressive strength less than .5 TSF; moist cohesive soil or moist dense sand which is not flowing or submerged. When cut with near vertical side walls, soil can stand with unsupported vertical sidewalls long enough for shoring installation. (see “1.c.”)

Type “C-80” Soil - Effective lateral weight of **80 PSF** per foot of depth.

Description: Cohesive soil with an unconfirmed compressive strength of .5 TSF or less; granular soils including gravel, sand, and loamy sand; submerged soil or soil from which water is freely seeping; submerged rock that is not stable; and material in a sloped, layered system where the layers dip into the excavation on a slope of four horizontal to one vertical (4H : 1V) or steeper.

SHORING PRODUCTS

Data Limitations

- A. When only the lower portion of a trench is to be shored and the remaining portion is benched or sloped at an angle steeper than three horizontal to one vertical (3H:1V), the allowable depth of excavation shall be measured from the top of the overall trench and not the toe of the sloped portion.
- B. In sloped excavations, the top of the shield must be a minimum of 18 inches above the bottom of the slope and the top struts/spreaders must be located below the bottom of the slope. In un-sloped excavations, the top of the shield may be flush with the ground surface, provided that the competent person determines that there is no hazard of objects rolling into the excavation.
- C. Modular Trench Shielding Systems shall be used with Manufacturer's adjustable struts/spreaders and static braces pinned in place with two (2) Manufacturer supplied 5/8" diameter pins at each end of the strut/spreader or brace as illustrated on page 5.
- D. Modular Trench Shielding Systems shall be assembled and installed as shown and in accordance with these instructions.
- E. Modular Trench Shielding Systems shall be handled by using the lifting lugs installed in holes provided in each panel or corner post. Stacking Brackets shall be used when stacking modular systems.
- F. The bottom of the Modular Shield shall be located no more than two feet from the bottom of the excavation in soil Types "A", "B" and "C-60\80" as long as no loss of soil from behind or below the shield is encountered. Proper benching of trench wall is required.

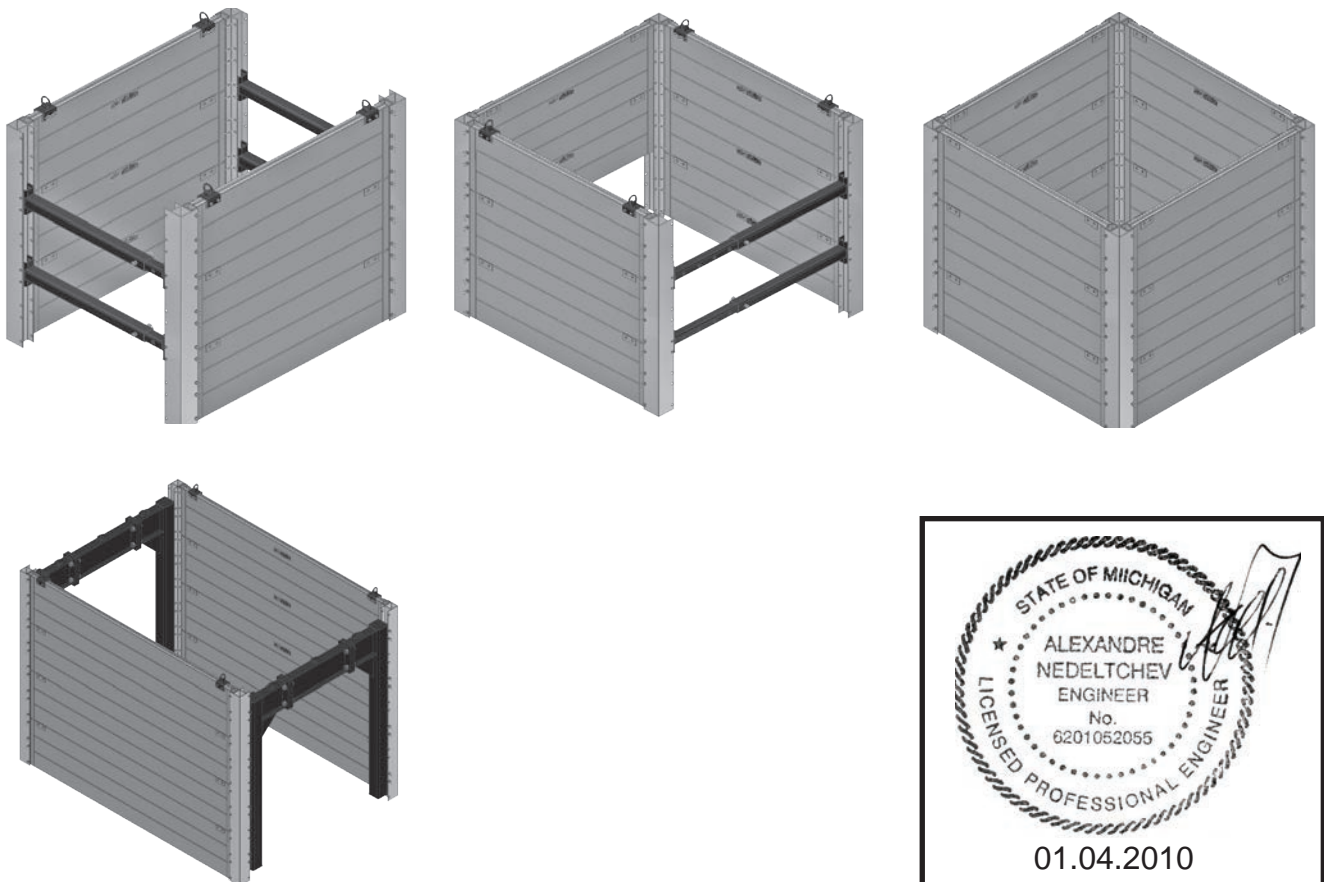



Two-sided configuration with telescoping spreaders and full length corner posts



Two-sided configuration with full length corner posts and arches



Two-sided configured with long spreaders for manole installation

Three-Sided Configurations



Three-sided configuration with telescoping spreaders and removed bottom panel



A three-sided configuration with end panels pinned 1 ft. up in corner posts allowing gas utility to run through



Three-sided configuration with spreaders on long side and removed bottom panels to straddle pipe

Four-Sided Configurations



Four-sided configuration with sectional corner posts and removed bottom panel



Long paneled four-sided configuration with sectional corner posts



Two, 8x8x8 ft. stacked Modular Shields with Stacking Guides

SHORING PRODUCTS

Assembly

Step 1

Attach 1st corner post to first panel and secure with pins and keepers.* Set the BACK panel for 3 or 4-sided system and secure with pins and keepers.*

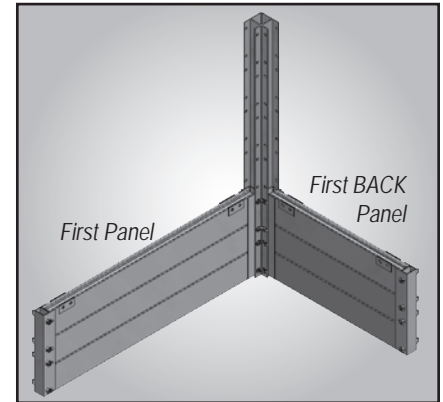
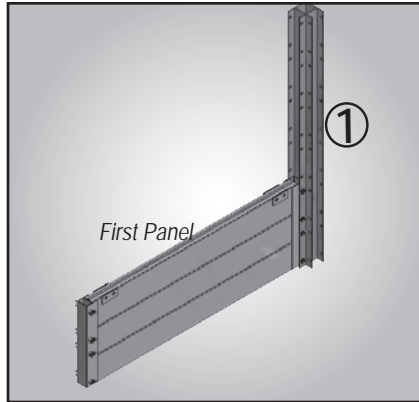

Step 2

Stack the SIDE and BACK panels to desired height before installing the 2nd and 3rd corner posts. Secure with pins and keepers.*

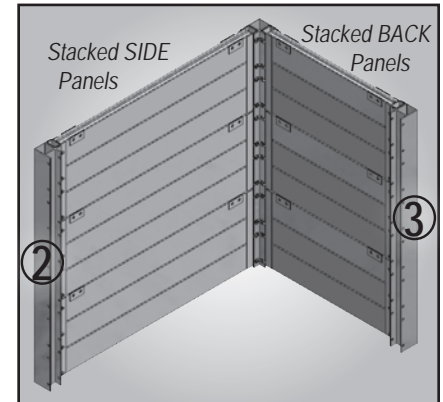
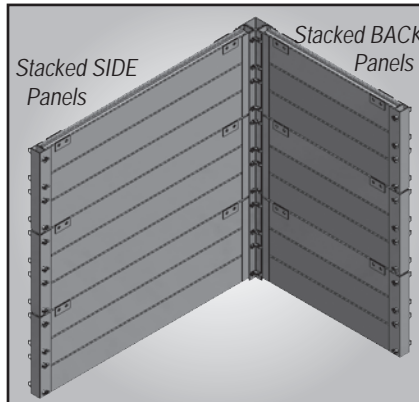

Step 3

Stack opposite SIDE panels to desired height, then add either a 4th wall of panels for a 4-sided system; or a set of at least two spreaders** for a 3-sided system.

Step 4

The 4th corner post can then be slid into place. Secure with pins and keepers.*

Note: A pry-bar may be needed to align posts with holes.

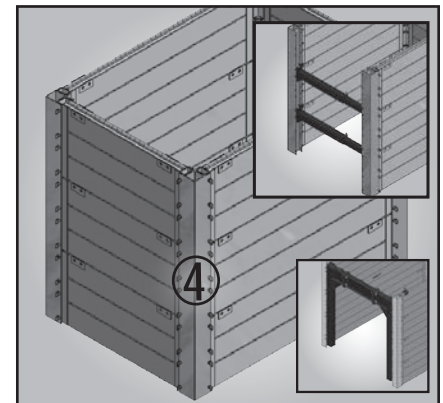
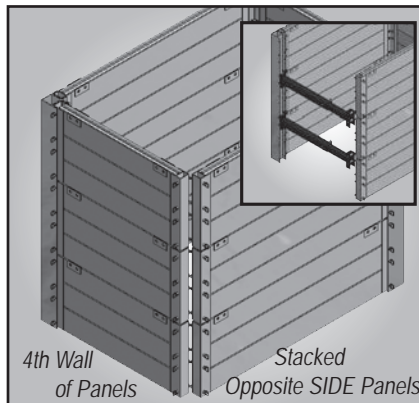

* Always install pins with handle on the outside; ** Arch or Sheeting Guide Frames can substitute spreaders

NOTES

1. Assemble on level ground.
2. Lift with factory supplied lift eyes.
3. System must be used in accordance to manufactures tabulated data.
4. Bottom panel may be omitted, allowing 2 feet open clearance, only if there is no possible loss of soil from behind or below the bottom of the shield.

[ASSEMBLY VIDEO](#)



SHORING PRODUCTS

Disassembly

NOTE: Remove pins & keepers one at a time from one spreader, post, or panel. **DO NOT REMOVE ALL PINS AND KEEPERS AT ONE TIME.**

Step 1

Unpin and remove *ONE* corner post connecting FRONT Panels (or spreaders) and SIDE Panels.

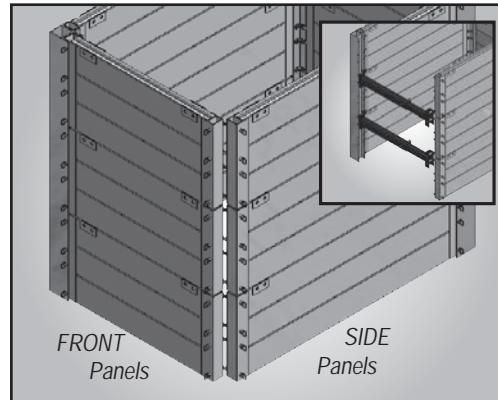

Step 2

Unpin and remove FRONT Panels (or spreaders) and SIDE Panels from corner posts; working from top to bottom.

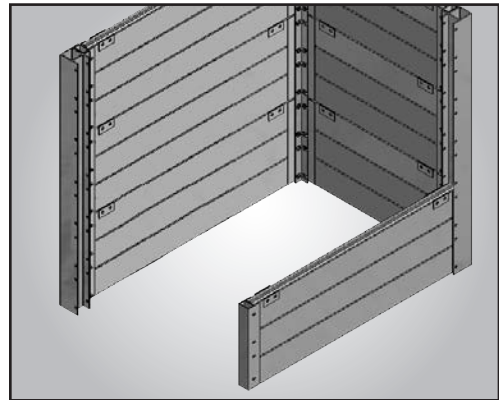

Step 3

Unpin and remove corner posts on open ends of remaining SIDE Panels and BACK Panels, leaving one corner post pinned to SIDE and BACK Panels. (This will keep the remaining system balanced.)

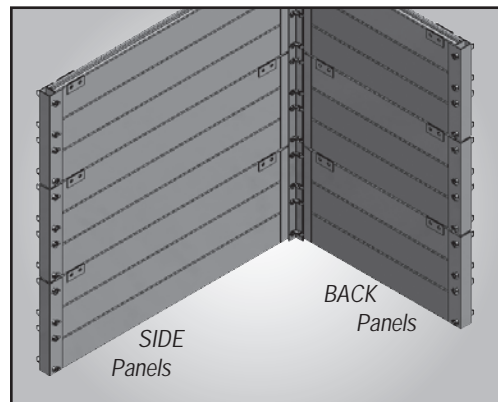

Step 4

Unpin and remove remaining panels from top to bottom, alternating between SIDE panels and BACK panels.

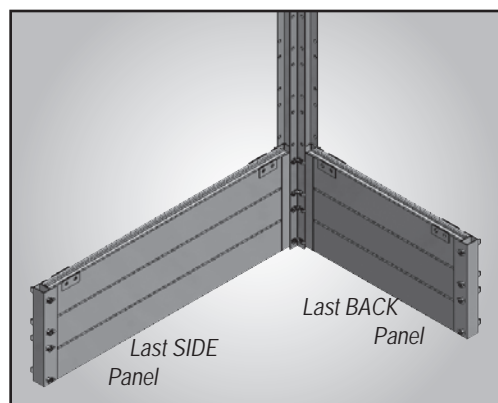

[DISASSEMBLY VIDEO](#)



NOTE: For 3-sided system, follow assembly procedures PAGE 5

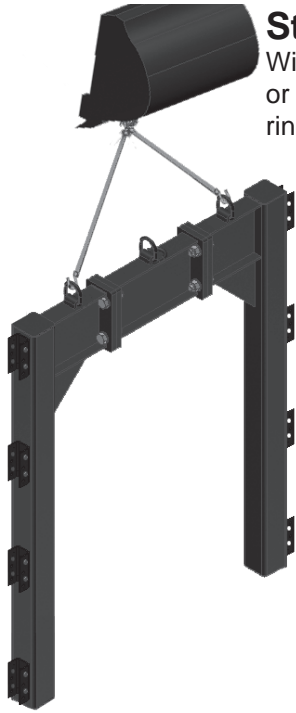

Step 1

With an excavator bucket or forklift, sling top lifting rings and standup Arch.

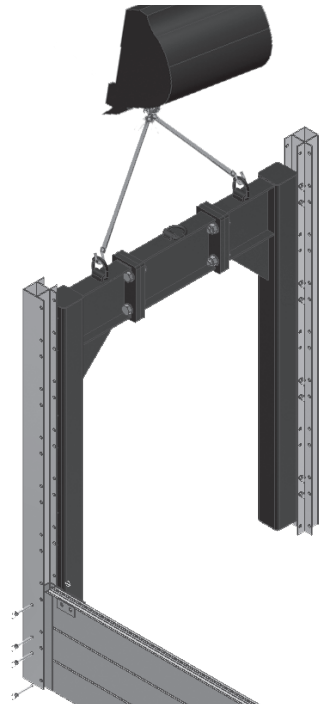

Step 2

With the Arch still supported, pin FULL-LENGTH Corner Posts 7' or longer onto Arches, and begin installing side panels. Secure Corner Posts and Panels with pins and keepers.

Step 3

Finish installing all Side Panels, alternating one side then the other. Secure with pins and keepers. Once system is 6' high, the Arch support can be removed.

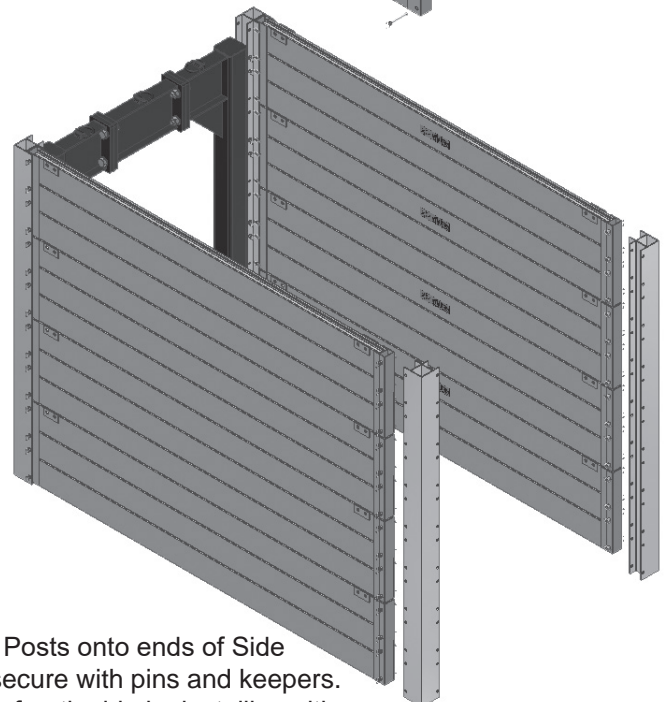
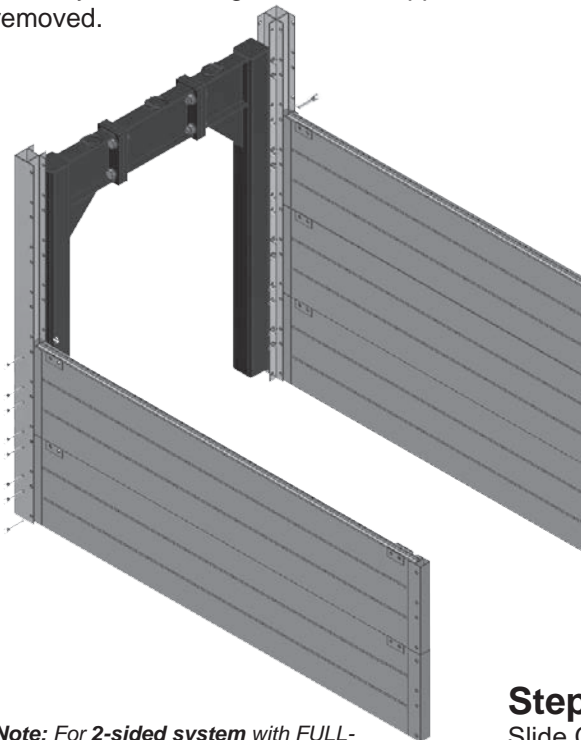

Step 4

Slide Corner Posts onto ends of Side Panels and secure with pins and keepers. Complete the fourth side by installing either spreaders, Sheeting Guide Frame, or another Arch.

Note: For 2-sided system with FULL-LENGTH Corner Posts, use chart on PAGE 15 for Depth. Use Vertical Clearance of 6'6" or less, and Horizontal Clearance of 14' or less.

Step 1

Excavate to grade just slightly wider than Modular Shield dimension. Dig walls vertical to minimum of 18 in. below the top of the box. Slope soil above box according to manufacturer's tabulated data.

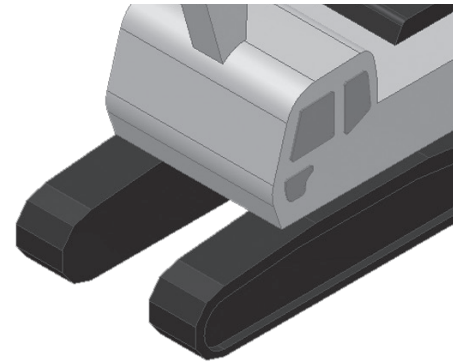
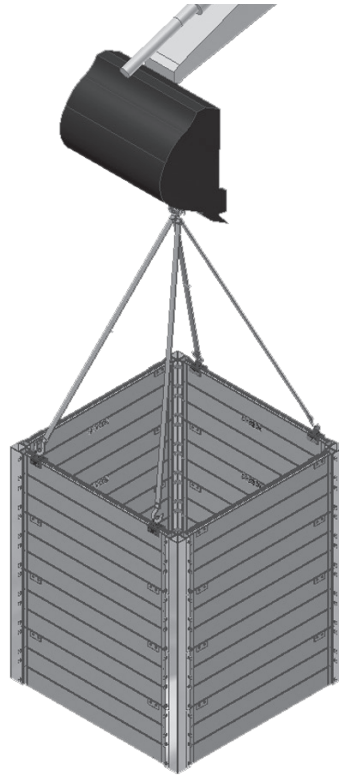

Step 2

Lower box into trench. Backfill between outside wall of the box and wall of the trench before use.

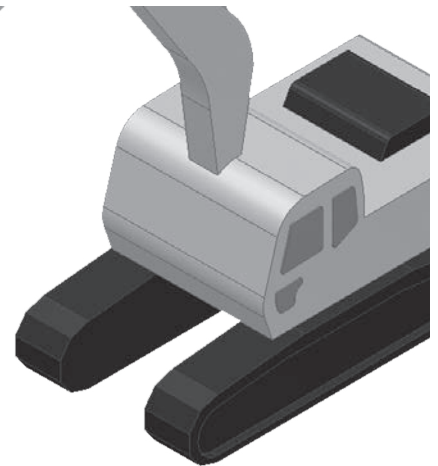
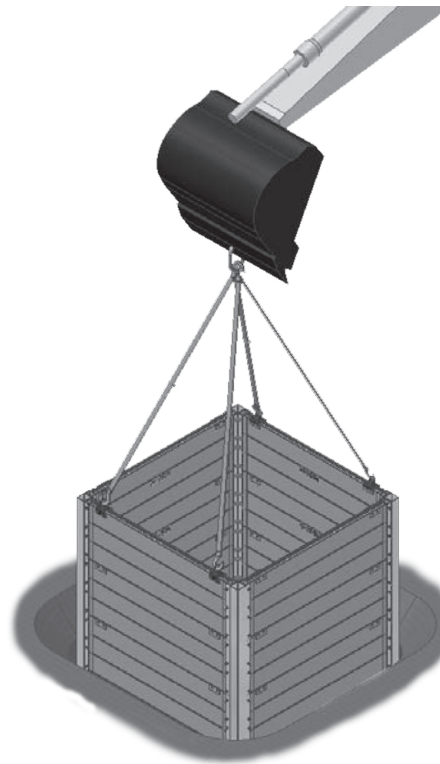

All Lifting Devices should be properly sized, designed, and used in compliance with all industry regulations and in conjunction with a trained and knowledgeable rigging and lifting expert's recommendations.

(1) Numerous other combinations of panels, corner posts, t-posts, 4-way posts and struts/spreaders, other than those shown on page 7, are permissible with approval from the manufacturer.

(2) Modular Shield panels each have four or six holes for connector pins on each side. A minimum of two of the four pins must be used in order for the manufacturer's tabulated data to remain valid. If sectional corner posts are used intersecting at the mid-point of the panel on the 2' high side, then a minimum of one pin must be used per on each of the two intersecting corner posts (two per panel). The other pins add rigidity and redundancy, but are not required.

(3) Modular Trench Shielding Systems, are designed for use with Manufacturer's adjustable struts/spreaders and static braces.

(4) Depth ratings are based on one strut/spreader per sectional corner post pair on 24 inch centers for the entire height of the system. Sectional corner posts must be installed in a manner to have the struts/spreaders centered on the posts and in line with the panel joints. Alternately, struts/spreaders may be used on 36 inch vertical centers if used with full length end posts. The full length end posts must extend to within 12 inches of the top and bottom of the panels. Full length corner posts may extend below the bottom of the panels to serve as legs; however depth of cut remains the same.

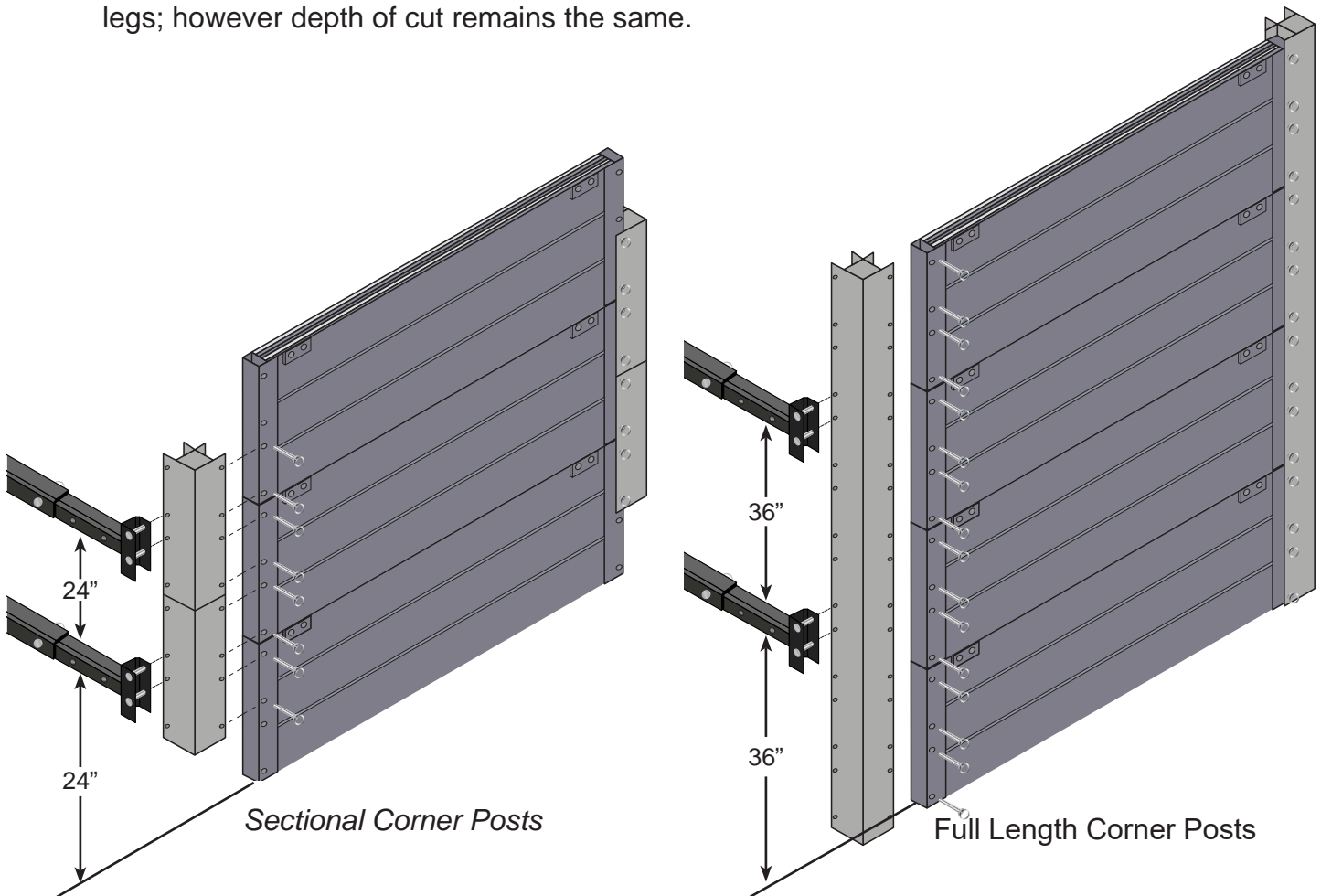

Struts/Spreaders on 24 or 36 in. vertical centers

2-Sided Modular Trench Shielding System						
Panel Selection Chart		Shield Capacity (PSF)	Depth of Cut (ft.) - Soil Type			
Ht. x Lg. (Ft.)	Weight (Lbs.)		A	B	C-60	C-80
BAB-22	28	2,400	96	53	40	30
BAB-23	40	2,400	96	53	40	30
BAB-24	52	2,400	96	53	40	30
BAB-25	64	2,400	96	53	40	30
BAB-26	76	2,400	96	53	40	30
BAB-27	88	1,740	70	39	29	22
BAB-28	100	1,440	58	32	24	18
BAB-29	112	1200	48	27	20	15
BAB-210	124	960	38	21	16	12
BAB-212	148	780	31	17	13	10
BAB-214	172	600	24	13	10	8
BAB-216	196	480	19	11	8	6

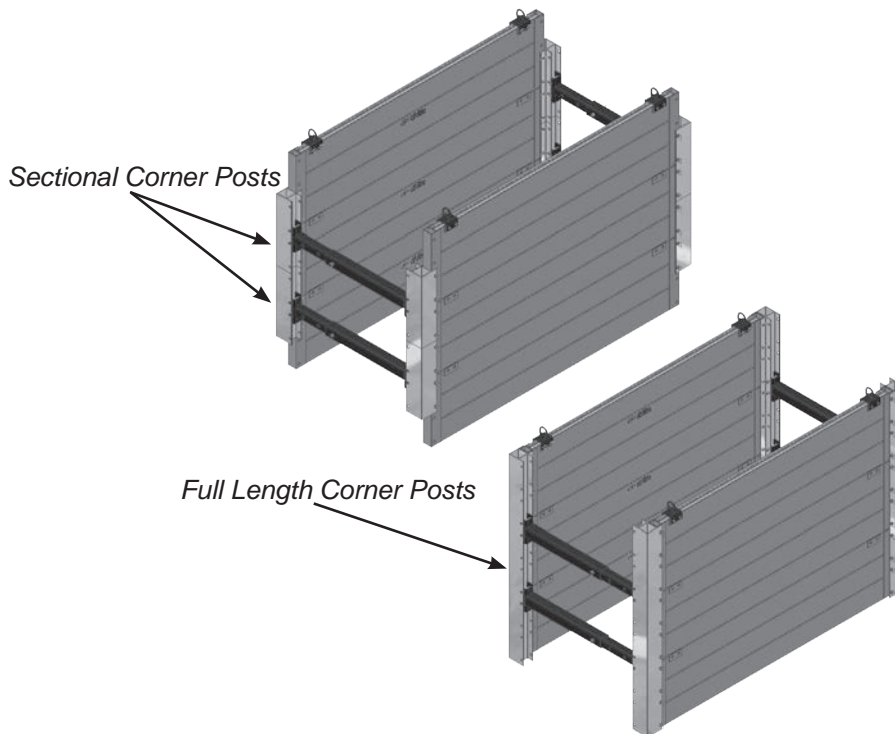

3 and 4 ft. Configurations

Struts/Spreader on 24 in. vertical centers on open end

3-Sided Modular Trench Shielding System					
Width x Length (Ft.)	Shield Capacity (PSF)	Depth of Cut (ft.) - Soil Type			
		A	B	C-60	C-80
3 X 2	2,160	86	48	36	27
3 X 3	2,160	86	48	36	27
3 X 4	2,160	86	48	36	27
3 X 5	2,100	84	47	35	26
3 X 6	2,040	82	45	34	25
3 X 7	1,740	70	39	29	21
3 X 8	1,440	58	32	24	18
3 X 9	1,200	48	27	20	15
3 X 10	960	38	21	16	12
3 X 12	780	31	17	13	9
3 X 14	600	24	13	10	7
3 X 16	480	19	11	8	6
4 X 2	2,160	86	48	36	27
4 X 4	2,160	86	48	36	27
4 X 5	2,100	84	47	35	26
4 X 6	2,040	82	45	34	25
4 X 7	1,620	65	36	27	20
4 X 8	1,320	53	29	22	16
4 X 9	1,200	48	27	20	15
4 X 10	900	36	20	15	11
4 X 12	780	31	17	13	9
4 X 14	600	24	13	10	7
4 X 16	480	19	11	8	6

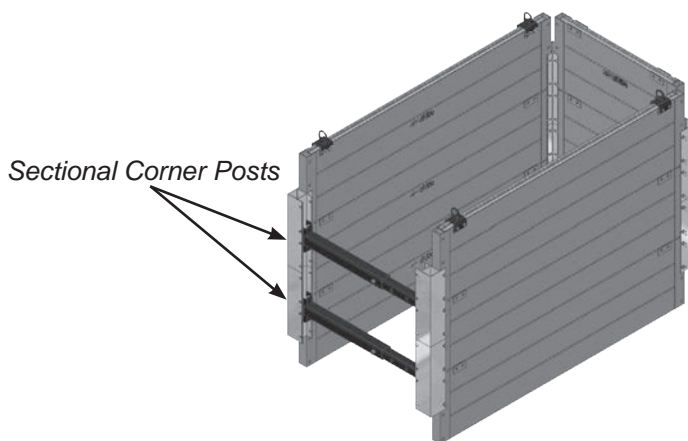

Notes: See Page 5

5 and 6 ft. Configurations

Struts/Spreaders on 24 in. vertical centers on open end

3-Sided Modular Trench Shielding System					
Width x Length (Ft.)	Shield Capacity (PSF)	Depth of Cut (ft.) - Soil Type			
		A	B	C-60	C-80
5 X 2	2,100	84	47	35	26
5 X 5	2,100	84	47	35	26
5 X 6	2,040	82	45	34	25
5 X 7	1,620	65	36	27	20
5 X 8	1,200	48	27	20	15
5 X 9	1,050	42	23	18	13
5 X 10	900	36	20	15	11
5 X 12	780	31	17	13	9
5 X 14	600	24	13	10	7
5 X 16	480	19	11	8	6
6 X 2	2,100	84	47	35	26
6 X 6	2,040	82	45	34	25
6 X 7	1,620	65	36	27	20
6 X 8	1,260	50	28	21	15
6 X 9	900	36	20	15	11
6 X 10	840	34	19	14	10
6 X 12	780	31	17	13	9
6 X 14	600	24	13	10	7
6 X 16	480	19	11	8	6

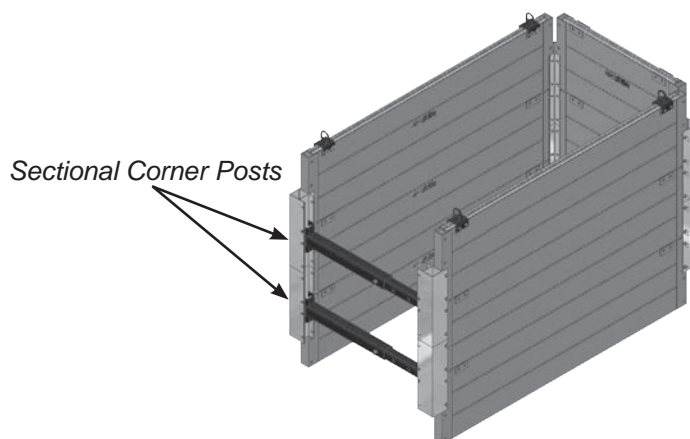

Notes: See Page 5

7, 8 and 9 ft. Configurations

Struts/Spreaders on 24 in. vertical centers on open end

3-Sided Modular Trench Shielding System					
Width x Length (Ft.)	Shield Capacity (PSF)	Depth of Cut (ft.) - Soil Type			
		A	B	C-60	C-80
7 X 2	1,740	70	39	29	21
7 X 7	1,620	65	36	27	20
7 X 8	1,200	48	27	20	15
7 X 9	1,020	41	23	17	12
7 X 10	840	34	19	14	10
7 X 12	720	29	16	12	9
7 X 14	540	22	12	9	6
7 X 16	480	19	11	8	6
8 X 2	1,620	65	36	27	20
8 X 8	1,200	48	27	20	15
8 X 9	1,020	41	23	17	12
8 X 10	840	34	19	14	10
8 X 12	720	29	16	12	9
8 X 14	540	22	12	9	6
8 X 16	480	19	11	8	6
9 X 2	1,200	48	27	20	15
9 X 9	1,020	41	23	17	12
9 X 10	840	34	19	14	10
9 X 12	720	29	16	12	9
9 X 14	540	22	12	9	6
9 X 16	480	19	11	8	6

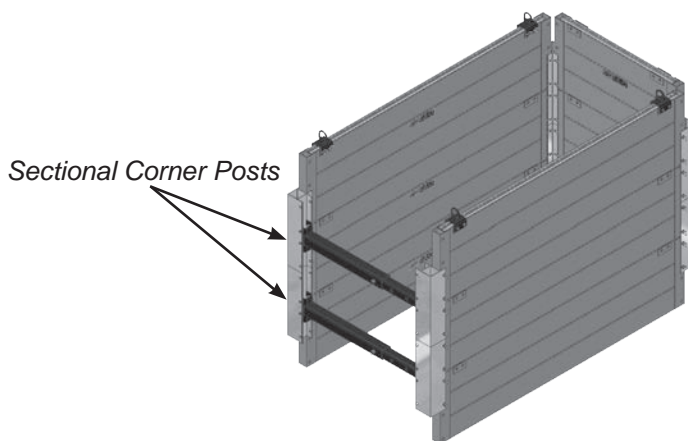

Notes: See Page 5

10, 12, 14, and 16 ft. Configurations

Struts/Spreaders on 24 in. vertical centers on open end

3-Sided Modular Trench Shielding System					
Width x Length (Ft.)	Shield Capacity (PSF)	Depth of Cut (ft.) - Soil Type			
		A	B	C-60	C-80
10 X 2	840	34	19	14	10
10 X 10	780	31	17	13	9
10 X 12	720	29	16	12	9
10 X 14	540	22	12	9	6
10 X 16	480	19	11	8	6
12 X 2	780	31	17	13	9
12 X 12	660	26	15	11	8
12 X 14	540	22	12	9	6
12 X 16	480	19	11	8	6
14 X 2	600	24	13	10	7
14 X 14	480	19	11	8	6
14 X 16	480	19	11	8	6
16 X 2	480	19	11	8	6
16 X 16	480	19	11	8	6

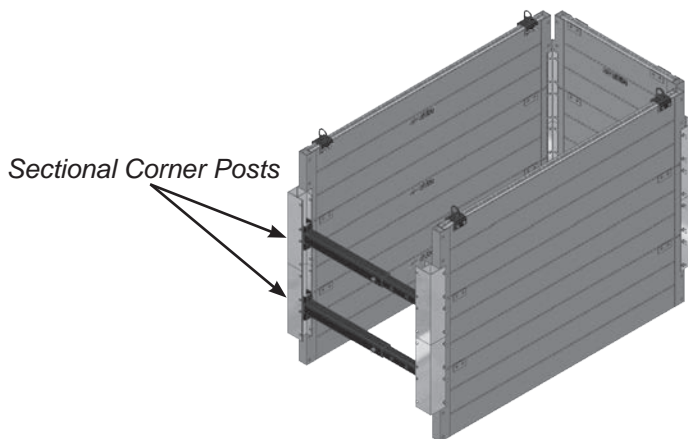

Notes: See Page 5

3 and 4 ft. Configurations

Struts/Spreaders on 36 in. vertical centers on open end

3-Sided Modular Trench Shielding System					
Width x Length (Ft.)	Shield Capacity (PSF)	Depth of Cut (ft.) - Soil Type			
		A	B	C-60	C-80
3 X 2	1,680	67	37	28	21
3 X 3	1,680	67	37	28	21
3 X 4	1,620	65	36	27	20
3 X 5	1,500	60	33	25	18
3 X 6	1,320	53	29	22	16
3 X 7	1,140	46	25	19	14
3 X 8	1,020	41	23	17	12
3 X 9	900	36	20	15	11
3 X 10	780	31	17	13	9
3 X 12	600	24	13	10	7
3 X 14	540	22	12	9	6
3 X 16	480	19	11	8	6
4 X 2	1,680	67	37	28	21
4 X 4	1,620	65	36	27	20
4 X 5	1,500	60	33	25	18
4 X 6	1,320	53	29	22	16
4 X 7	1,140	46	25	19	14
4 X 8	1,020	41	23	17	12
4 X 9	900	36	20	15	11
4 X 10	780	31	17	13	9
4 X 12	600	24	13	10	7
4 X 14	540	22	12	9	6
4 X 16	480	19	11	8	6

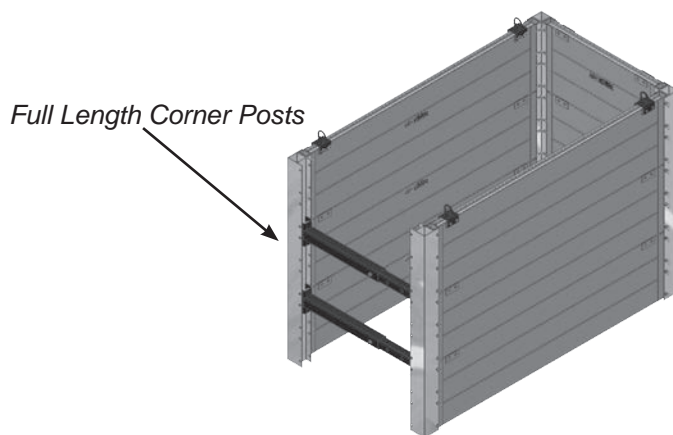

Notes: See Page 5

5 and 6 ft. Configurations

Struts/Spreaders on 36 in. vertical centers on open end

3-Sided Modular Trench Shielding System					
Width x Length (Ft.)	Shield Capacity (PSF)	Depth of Cut (ft.) - Soil Type			
		A	B	C-60	C-80
5 X 2	1,620	65	36	27	20
5 X 5	1,500	60	33	25	18
5 X 6	1,320	53	29	22	16
5 X 7	1,140	46	25	19	14
5 X 8	1,020	41	23	17	12
5 X 9	870	35	19	15	10
5 X 10	720	29	16	12	9
5 X 12	600	24	13	10	7
5 X 14	540	22	12	9	6
5 X 16	480	19	11	8	6
6 X 2	1,560	62	35	26	19
6 X 6	1,320	53	29	22	16
6 X 7	1,140	46	25	19	14
6 X 8	1,020	41	23	17	12
6 X 9	870	35	19	15	10
6 X 10	720	29	16	12	9
6 X 12	600	24	13	10	7
6 X 14	540	22	12	9	6
6 X 16	480	19	11	8	6

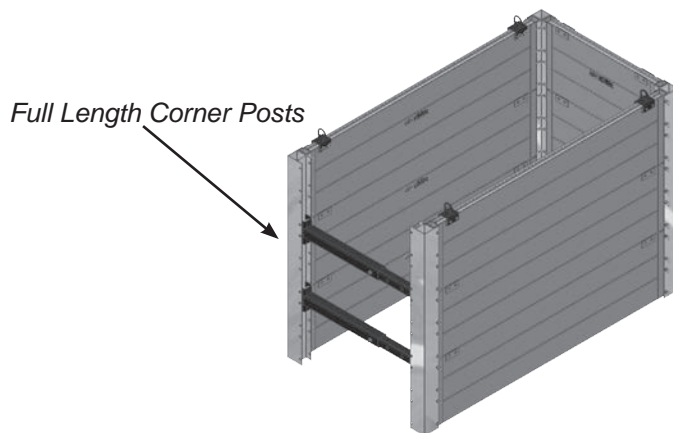

Notes: See Page 5

7, 8 and 9 ft. Configurations

Struts/Spreaders on 36 in. vertical centers on open end

3-Sided Modular Trench Shielding System					
Width x Length (Ft.)	Shield Capacity (PSF)	Depth of Cut (ft.) - Soil Type			
		A	B	C-60	C-80
7 X 2	1,560	62	35	26	19
7 X 7	1,140	46	25	19	14
7 X 8	1,020	41	23	17	12
7 X 9	870	35	19	15	10
7 X 10	720	29	16	12	9
7 X 12	600	24	13	10	7
7 X 14	540	22	12	9	6
7 X 16	480	19	11	8	6
8 X 2	144	6	3	2	1
8 X 8	1,020	41	23	17	12
8 X 9	870	35	19	15	10
8 X 10	720	29	16	12	9
8 X 12	540	22	12	9	6
8 X 14	480	19	11	8	6
8 X 16	480	19	11	8	6
9 X 2	1,200	48	27	20	15
9 X 9	810	32	18	14	10
9 X 10	720	29	16	12	9
9 X 12	540	22	12	9	6
9 X 14	480	19	11	8	6
9 X 16	480	19	11	8	6

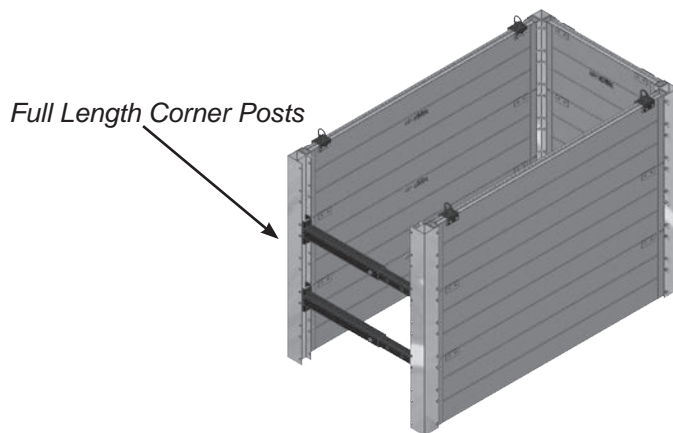

Notes: See Page 5

10, 12, 14, and 16 ft. Configurations

Struts/Spreaders on 36 in. vertical centers on open end

3-Sided Modular Trench Shielding System					
Width x Length (Ft.)	Shield Capacity (PSF)	Depth of Cut (ft.) - Soil Type			
		A	B	C-60	C-80
10 X 2	960	38	21	16	12
10 X 10	660	26	15	11	8
10 X 12	540	22	12	9	6
10 X 14	480	19	11	8	6
10 X 16	480	19	11	8	6
12 X 2	780	31	17	13	9
12 X 12	540	22	12	9	6
12 X 14	480	19	11	8	6
12 X 16	480	19	11	8	6
14 X 2	600	24	13	10	7
14 X 14	480	19	11	8	6
14 X 16	480	19	11	8	6
16 X 2	480	19	11	8	6
16 X 16	480	19	11	8	6

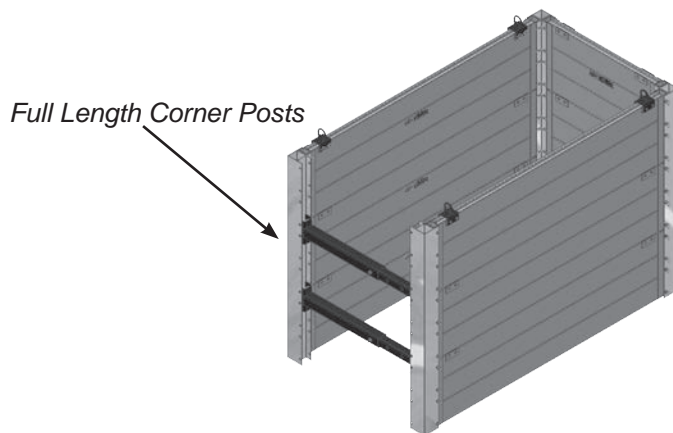

Notes: See Page 5

3 and 4 ft. Configurations

4-Sided Modular Trench Shielding System					
Width x Length (Ft.)	Shield Capacity (PSF)	Depth of Cut (ft.) - Soil Type			
		A	B	C-60	C-80
3 X 2	2,160	86	48	36	27
3 X 3	2,160	86	48	36	27
3 X 4	2,160	86	48	36	27
3 X 5	2,100	84	47	35	26
3 X 6	2,040	82	45	34	25
3 X 7	1,740	70	39	29	21
3 X 8	1,440	58	32	24	18
3 X 9	1,200	48	27	20	15
3 X 10	960	38	21	16	12
3 X 12	780	31	17	13	9
3 X 14	600	24	13	10	7
3 X 16	480	19	11	8	6
4 X 2	2,160	86	48	36	27
4 X 4	2,160	86	48	36	27
4 X 5	2,100	84	47	35	26
4 X 6	2,040	82	45	34	25
4 X 7	1,620	65	36	27	20
4 X 8	1,320	53	29	22	16
4 X 9	1,200	48	27	20	15
4 X 10	900	36	20	15	11
4 X 12	780	31	17	13	9
4 X 14	600	24	13	10	7
4 X 16	480	19	11	8	6

Sectional
Corner Posts

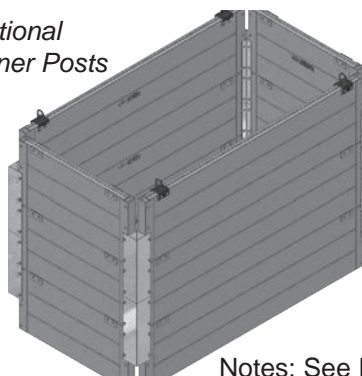

Notes: See Page 5

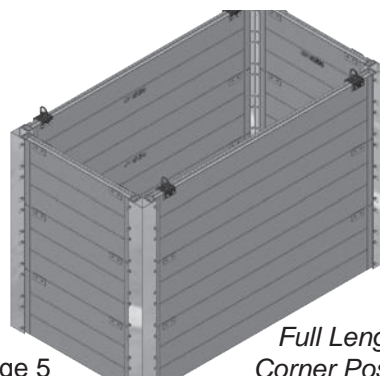

Full Length
Corner Posts



5 and 6 ft. Configurations

4-Sided Modular Trench Shielding System					
Width x Length (Ft.)	Shield Capacity (PSF)	Depth of Cut (ft.) - Soil Type			
		A	B	C-60	C-80
5 X 2	2,100	84	47	35	26
5 X 5	2,100	84	47	35	26
5 X 6	2,040	82	45	34	25
5 X 7	1,620	65	36	27	20
5 X 8	1,200	48	27	20	15
5 X 9	1,050	42	23	18	13
5 X 10	900	36	20	15	11
5 X 12	780	31	17	13	9
5 X 14	600	24	13	10	7
5 X 16	480	19	11	8	6
6 X 2	2,100	84	47	35	26
6 X 6	2,040	82	45	34	25
6 X 7	1,620	65	36	27	20
6 X 8	1,260	50	28	21	15
6 X 9	900	36	20	15	11
6 X 10	840	34	19	14	10
6 X 12	780	31	17	13	9
6 X 14	600	24	13	10	7
6 X 16	480	19	11	8	6

Sectional
Corner Posts

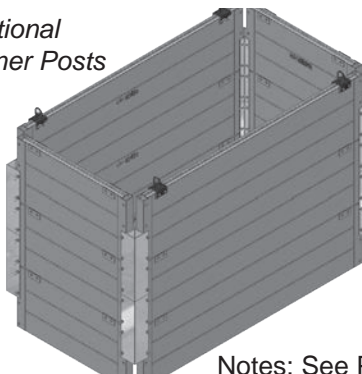

Notes: See Page 5

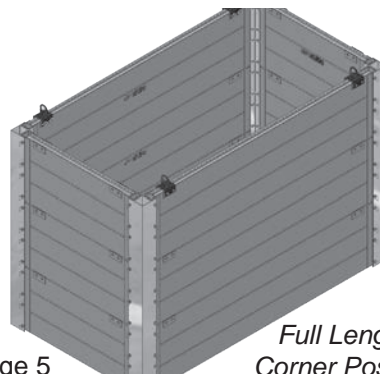

Full Length
Corner Posts



7, 8 and 9 ft. Configurations

4-Sided Modular Trench Shielding System					
Width x Length (Ft.)	Shield Capacity (PSF)	Depth of Cut (ft.) - Soil Type			
		A	B	C-60	C-80
7 X 2	1,740	70	39	29	21
7 X 7	1,620	65	36	27	20
7 X 8	1,200	48	27	20	15
7 X 9	1,020	41	23	17	12
7 X 10	840	34	19	14	10
7 X 12	720	29	16	12	9
7 X 14	540	22	12	9	6
7 X 16	480	19	11	8	6
8 X 2	1,620	65	36	27	20
8 X 8	1,200	48	27	20	15
8 X 9	1,020	41	23	17	12
8 X 10	840	34	19	14	10
8 X 12	720	29	16	12	9
8 X 14	540	22	12	9	6
8 X 16	480	19	11	8	6
9 X 2	1,200	48	27	20	15
9 X 9	1,020	41	23	17	12
9 X 10	840	34	19	14	10
9 X 12	720	29	16	12	9
9 X 14	540	22	12	9	6
9 X 16	480	19	11	8	6

Sectional
Corner Posts

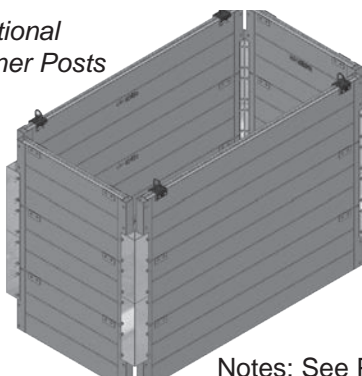

Notes: See Page 5

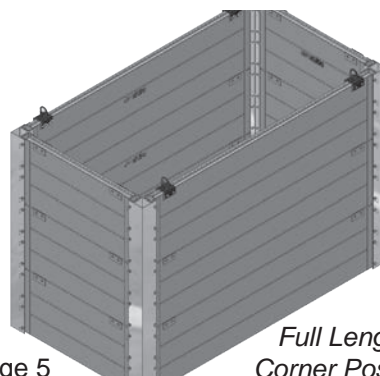

Full Length
Corner Posts



10, 12, 14, and 16 ft. Configurations

4-Sided Modular Trench Shielding System					
Width x Length (Ft.)	Shield Capacity (PSF)	Depth of Cut (ft.) - Soil Type			
		A	B	C-60	C-80
10 X 2	840	34	19	14	10
10 X 10	780	31	17	13	9
10 X 12	720	29	16	12	9
10 X 14	540	22	12	9	6
10 X 16	480	19	11	8	6
12 X 2	780	31	17	13	9
12 X 12	660	26	15	11	8
12 X 14	540	22	12	9	6
12 X 16	480	19	11	8	6
14 X 2	600	24	13	10	7
14 X 14	480	19	11	8	6
14 X 16	480	19	11	8	6
16 X 2	480	19	11	8	6
16 X 16	480	19	11	8	6

Sectional
Corner Posts

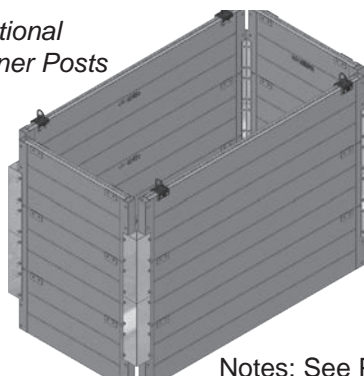

Notes: See Page 5

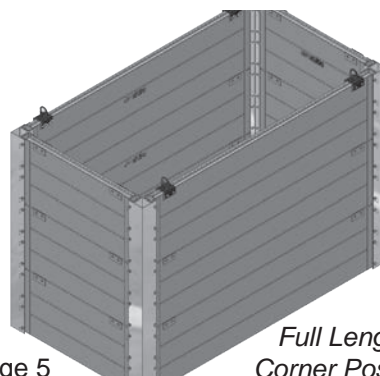

Full Length
Corner Posts



Sectional Corner Posts

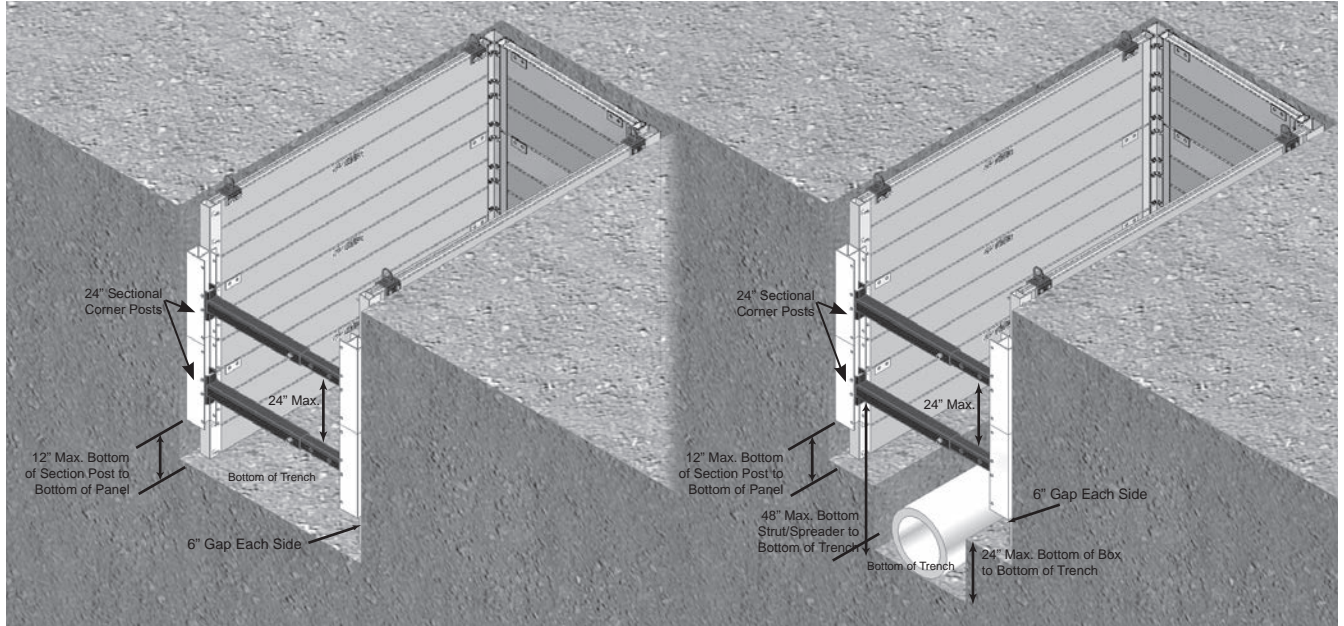

Full Length Corner Posts

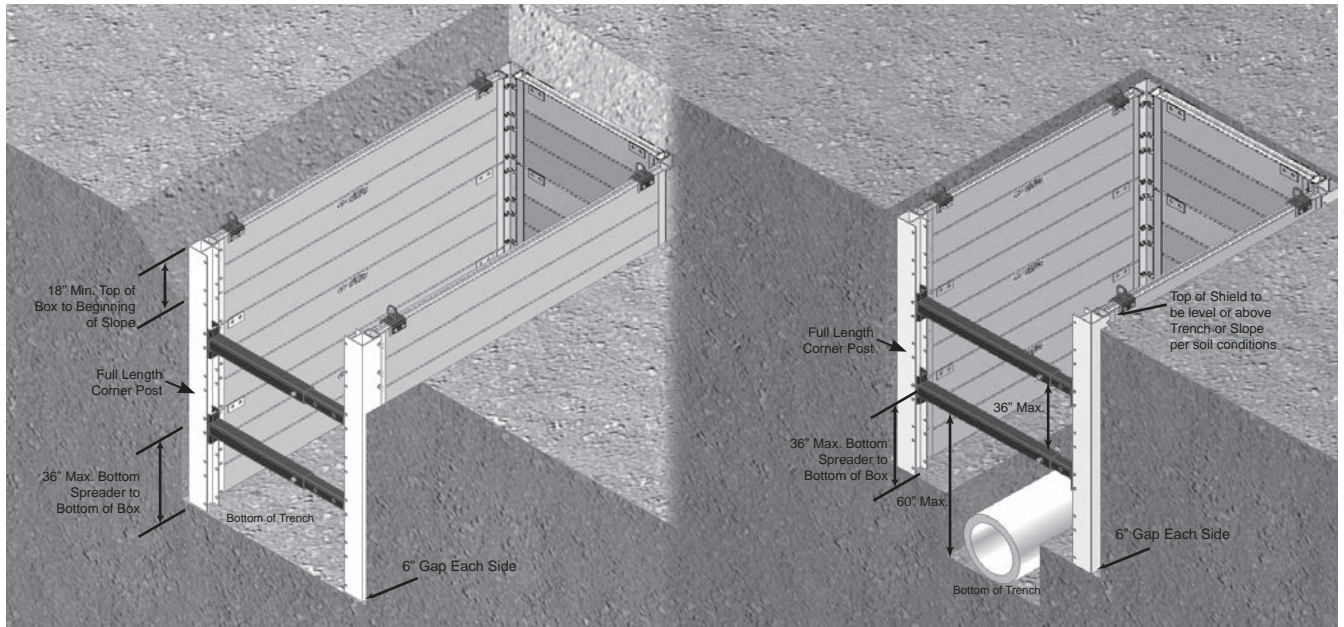

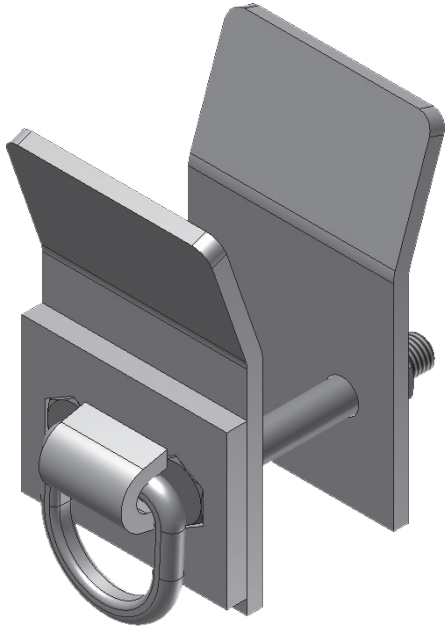

BUILD-A-BOX STACKING GUIDE

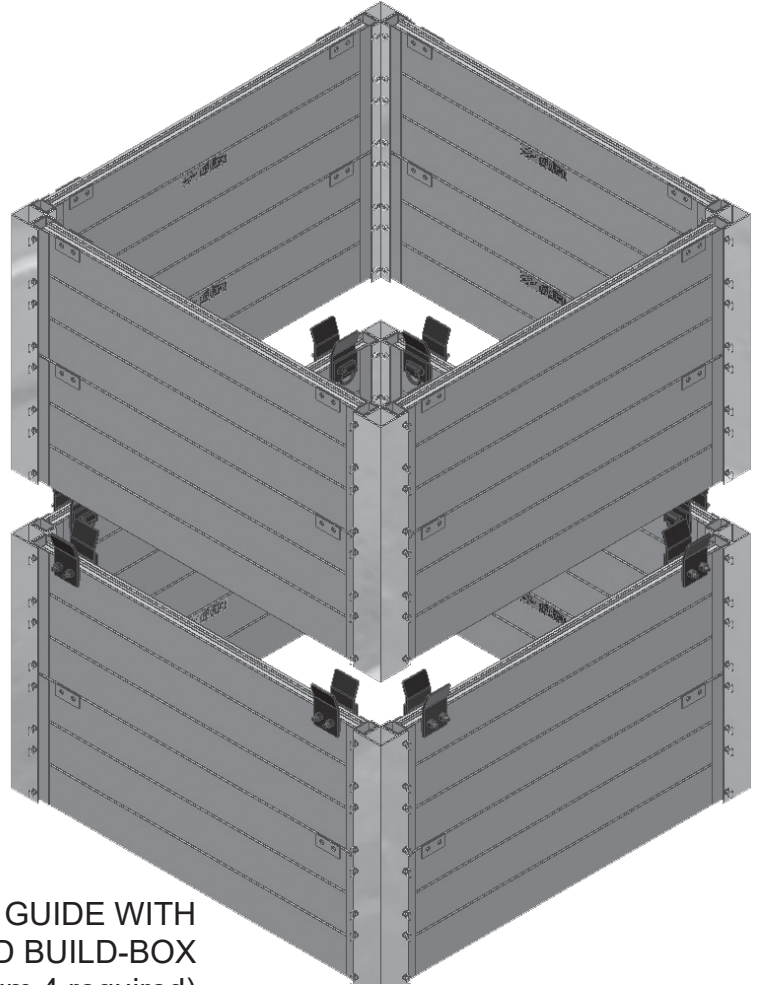

STACKING GUIDE WITH
4-SIDED BUILD-BOX
(Minimum 4 required)

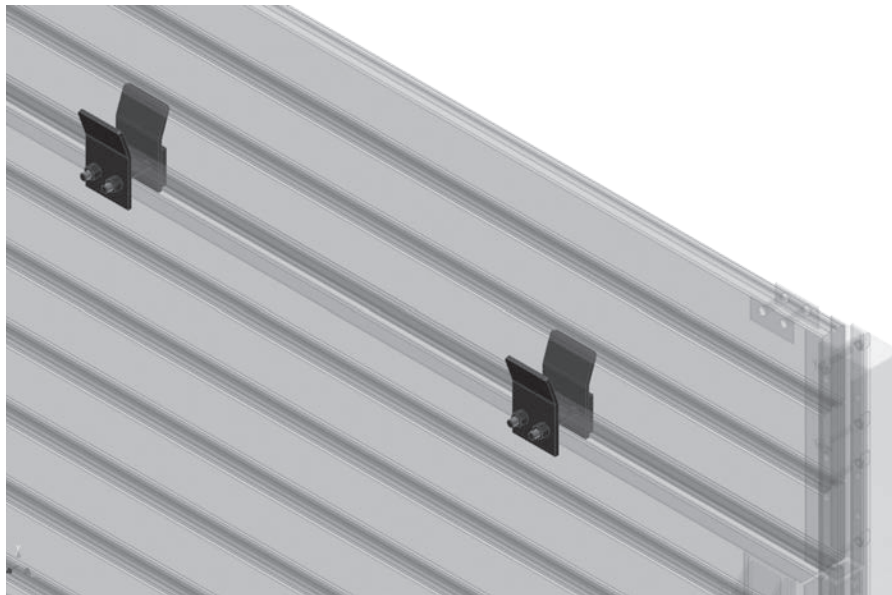

BUILD-A-BOX PANEL
STACKED ON (EPI) ALU-
MINUM TRENCH SHIELD
WITH STACKING GUIDES

Two-sided (EPI) Aluminum Shield with Stacked Modular Panel

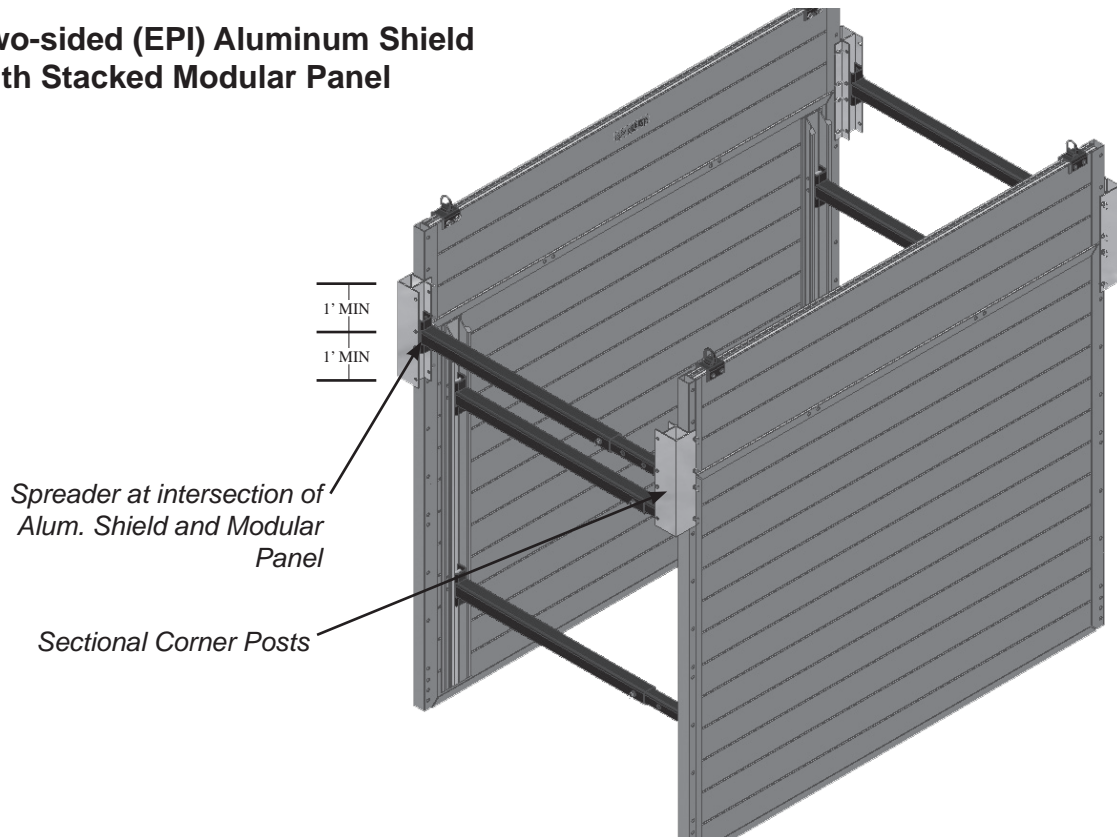

Three-sided (EPI) Alum. Shield with Stacked Modular Panels

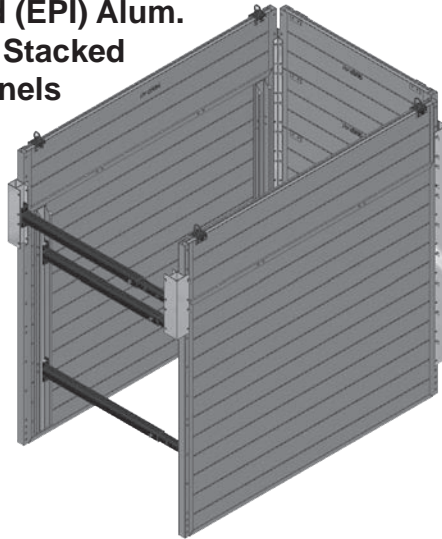

Four-sided (EPI) Alum. Shield with Stacked Modular Panels

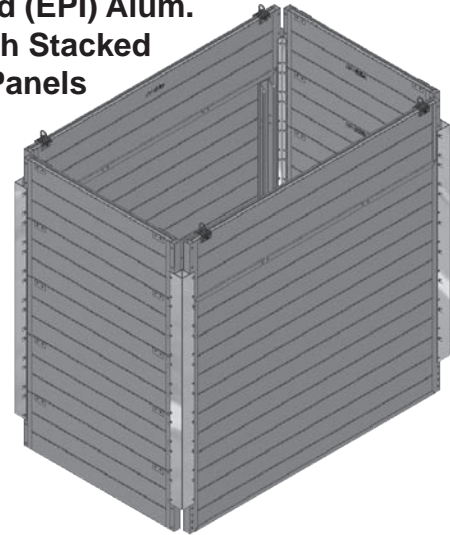

1. Corner Posts must extend a minimum of 1 ft. both below and above the intersection of the Modular Shield panel on the Aluminum Trench Shield
2. For two and three-sided systems, spreaders must be located at the intersection of the Modular Panel and the Aluminum Trench Shield, and vertically per the Tabulated Data.
3. Follow the Tabulated Data charts for additional stacked Modular Shield assemblies.

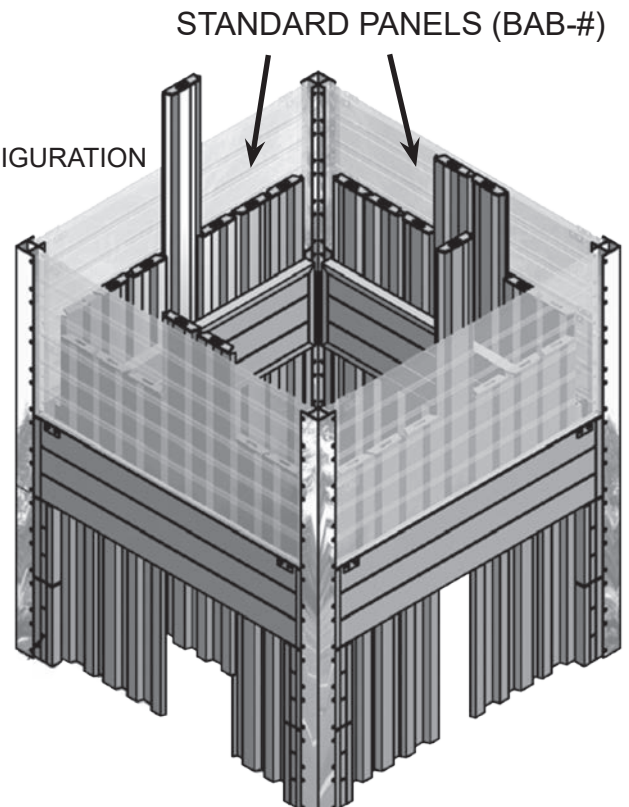
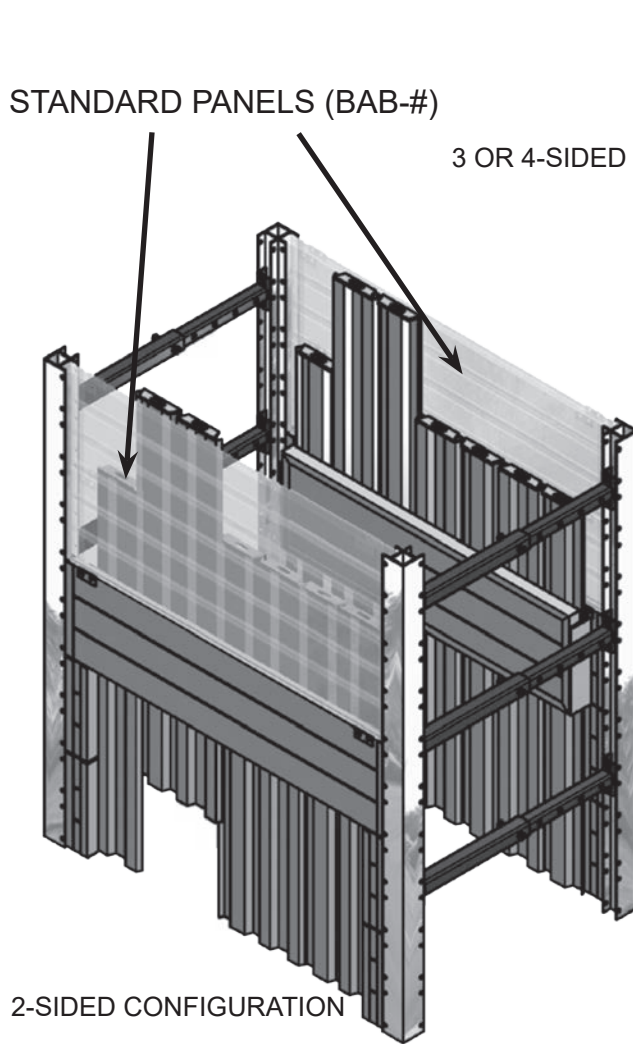

NOTES:

1. Build-A-Box Guide Frames will replace standard panels in any configuration
2. For use with Full-Length Corner Posts only
3. All pins and keepers must be installed into guide frame
4. Guide frames must be offset to the inside of the excavation
5. At least one standard Build-A-Box panel must be installed above the guide frame

Build-A-Box™ Sheeting Guide Frame													
Frame Selection Chart		Shield Capacity & Maximum Depth of Cut (ft.)											
		4 ft. Cantilever				3 ft. Cantilever				2 ft. Cantilever			
Length (Ft.)	Weight (Lbs.)	Sh. Cap	B	C-60	C-80	Sh. Cap	B	C-60	C-80	Sh. Cap	B	C-60	C-80
BBAC-GF-4	118	600	13	10	8	780	17	13	10	960	21	16	12
BBAC-GF-6	166	600	13	10	8	780	17	13	10	960	21	16	12
BBAC-GF-8	215	600	13	10	8	780	17	13	10	960	21	16	12
BBAC-GF-10	300	600	13	10	8	780	17	13	10	960	21	16	12
BBAC-GF-12	385	600	13	10	8	780	17	13	10	780	17	13	10
BBAC-GF-14	550	600	13	10	8	600	13	10	8	600	13	10	8
BBAC-GF-16	635	480	11	8	6	480	11	8	6	480	11	8	6

DATE: May 29, 2019

SUBJECT: Build-A Box System Octagon Configuration

General Notes:

This Technical Data Sheet is in addition to EPI's Tabulated Data for **Build-A-Box Modular Trench Shielding System**.

- All personnel involved with the use of the *Build-A Box System Octagon Configuration* shall be trained in the proper use and installation procedures and other applicable safety requirements.
- The maximum depth of the excavation shall not exceed **20-ft.** and the soil is classified as **C60 soil** in accordance with the above referenced Tabulated Data.
- The Build-A Box System Octagon Configuration shall have a **minimum height of 6-ft.**
- All components shall be positioned in accordance with **Figure(1.1)** and **Table (1.1)** prior to employees entering the excavation. Refer to the installation procedures for typical installation figures.
- The system shall be installed in a manner to prevent lateral or otherwise hazardous movement. The Build-A Box panels shall backfilled against at least 2/3 of the total height of the configuration.
- This data is valid for components in structurally sound condition. Any significant damage will void this data, and all manufacturers' warranty. The damaged components shall not be used.
- Bottom panels may be left out as indicated in **Figure(1.2)**.
- Surcharge loads are not included in the maximum depth tables. Surcharge loads are possible due to heavy equipment, vibrations, or soil piles adjacent to the trench. (Adjacent is defined as within a distance equal to the depth of the trench.)

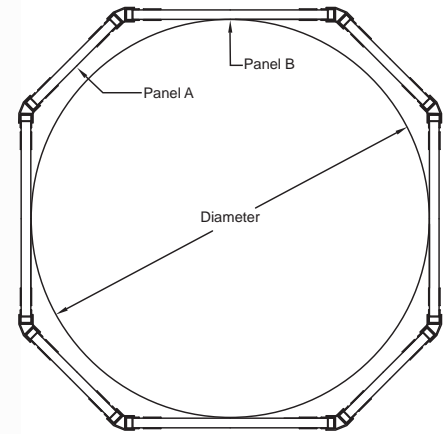

Plan View

Figure (1.1)

Diameter	Panel A	Panel B
61-in	BAB-2	BAB-2
73-in	BAB-2	BAB-3
85-in	BAB-2	BAB-4
90-in	BAB-3	BAB-3
97-in	BAB-2	BAB-5
102-in	BAB-3	BAB-4
114-in	BAB-3	BAB-5
119-in	BAB-4	BAB-4
131-in	BAB-4	BAB-5
148-in	BAB-5	BAB-5

Table (1.1)

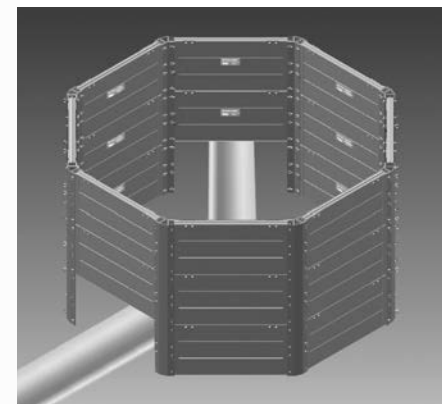
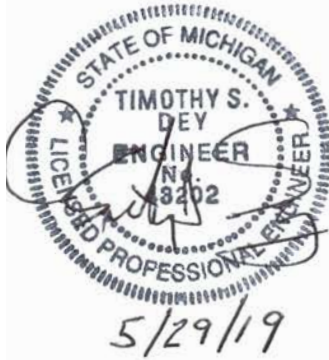
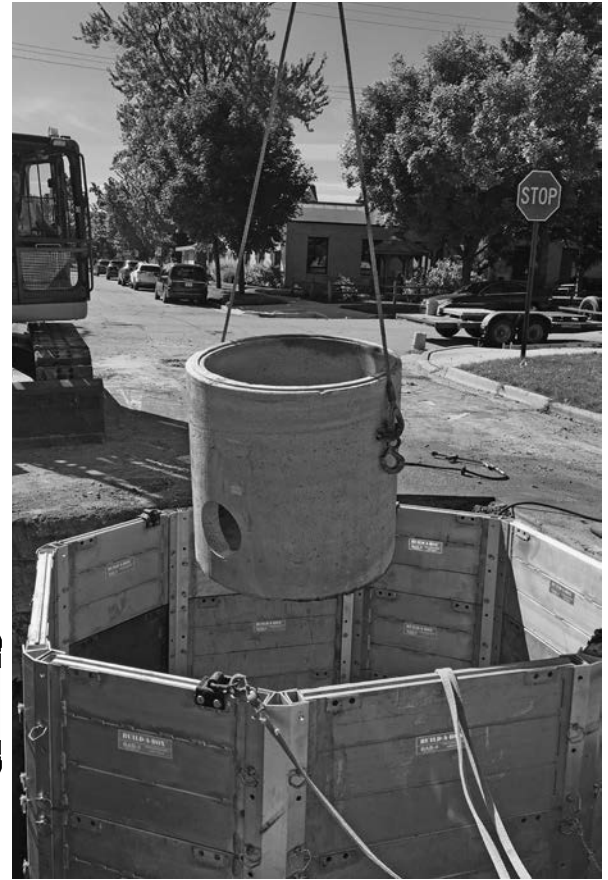
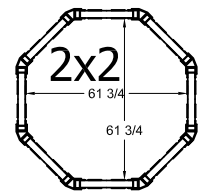
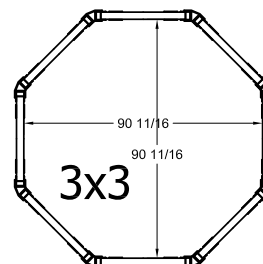
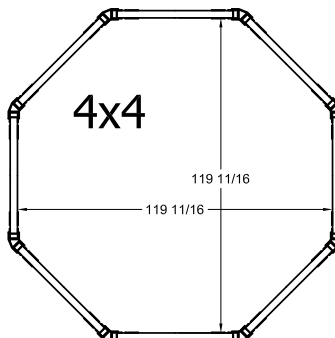
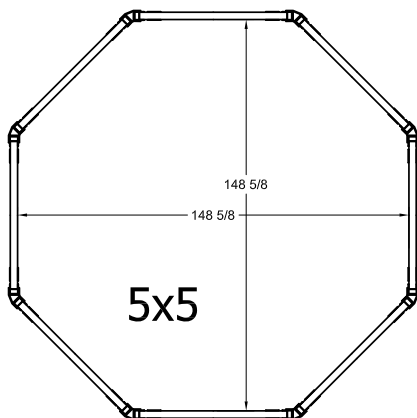
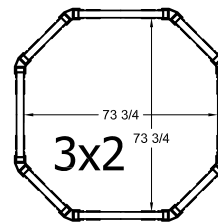
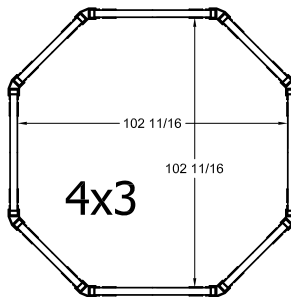
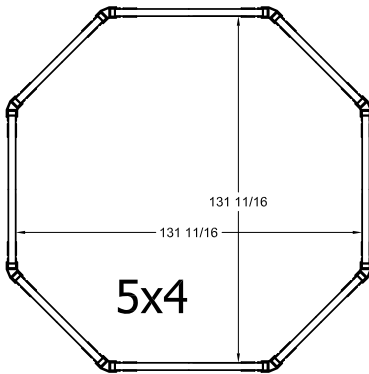
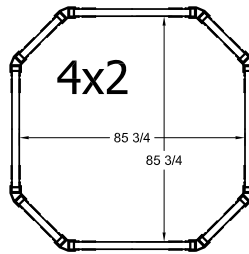
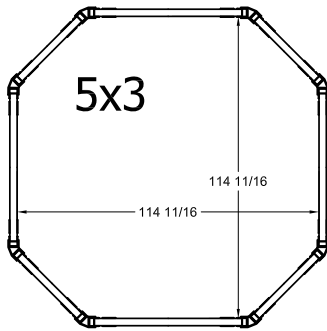
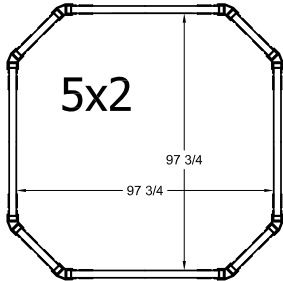



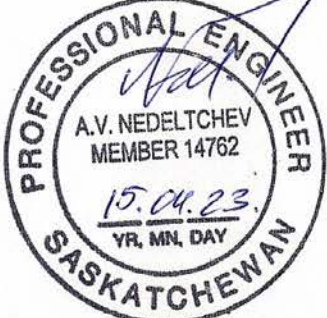



Figure (1.2)



SHORING PRODUCTS

Additional Certifications

The following additional certifications apply to pages 1-28 of this document.

 <p>LICENSED PROFESSIONAL ENGINEER A.V. NEDELTCHEV 04.23.15 PROVINCE OF ONTARIO</p>	 <p>PROFESSIONAL ENGINEER ALBERTA ALEX NEDELTCHEV 04.23.2015</p>	 <p>PROFESSIONAL ENGINEER A.V. NEDELTCHEV MEMBER 14762 15.04.23 YR. MN. DAY SASKATCHEWAN</p>
 <p>REGISTERED PROFESSIONAL ENGINEER DATE 04.23.2015 A.V. NEDELTCHEV 3001 PROVINCE OF NOVA SCOTIA</p>	 <p>PROFESSIONAL ENGINEER PROVINCE OF BRITISH COLUMBIA A. NEDELTCHEV # 31609 04.23.2015</p>	 <p>PROVINCE OF MANITOBA REGISTERED PROFESSIONAL ENGINEER A.V. NEDELTCHEV Member 33107 04.23.2015</p>
 <p>STATE OF MICHIGAN ALEXANDRE NEDELTCHEV ENGINEER No. 6201052055 LICENSED PROFESSIONAL ENGINEER 04.23.2015</p>		